

Our Trent XWB SES Core Stand, compatible with the XWB-84k and XWB-97k variants, is fully functional for air, road, and sea freight transportation. The whole engine or QECU can be transported by air via Airbus Beluga or Antonov, while the core engine can be transported via B747F or B777F. The stand has been load tested to 2x WLL and has guiding and fixing features that allows it to be properly aligned to the fan stand for engine split. Adjustments can be made to the intermediate and upper frame in the longitudinal and vertical direction by hand wheel, lever, and power drill.

## KEY FEATURES

- 1 Shock attenuation system prevents engine damage during transportation

---

- 2 Can be lifted both empty and loaded with forklift or crane and interfacing equipment

---

- 3 Integral Air-Freight Pallet

---

- 4 Retractable swivel castors and stowable tow bars enable local transportation

---

- 5 14 tie down points

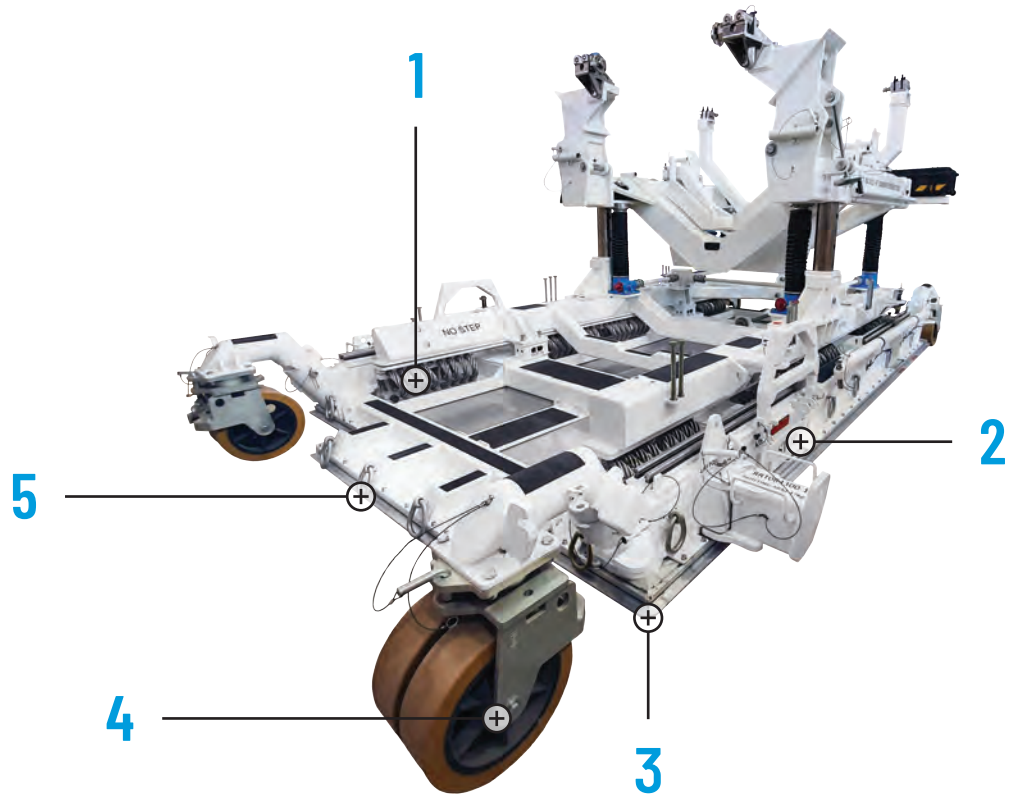

## SPECIFICATIONS

STAND	WEIGHT	DIMENSIONS
EMPTY	18,739 lbs (8,500 kg)	206"L x 117"W x 96"H (5,232mm x 2,972mm x 2,450mm)
STAND + WHOLE ENGINE (-84)	36,994 lbs (16,780 kg)	298"L x 142"W x 168"H (7,582mm x 3,605mm x 4,277mm)
STAND + WHOLE ENGINE (-97)	37,765 lbs (17,130 kg)	298"L x 142"W x 168"H (7,582mm x 3,605mm x 4,277mm)
STAND + CORE ENGINE (-84)	29,630 lbs (13,440 kg)	298"L x 118"W x 133"H (7,582mm x 2,986mm x 3,388mm)
STAND + CORE ENGINE (-97)	30,358 lbs (13,770 kg)	298"L x 118"W x 133"H (7,582mm x 2,986mm x 3,388mm)



Our Trent XWB SES Fan Stand, compatible with the XWB-84k and XWB-97k variants, is fully functional for air, road, and sea freight transportation. The fan case can be transported by air via B747F or B777F. The stand can be lifted both empty and loaded with a forklift or crane and interfacing equipment and has been load tested to 2x WLL.

## KEY FEATURES

- 1 Retractable swivel castors
- 2 3-axis hydraulic rotation system for proper alignment during split and reassembly of engine
- 3 Fan can be rotated 90° to reduce the clearance height while shipping
- 4 Shock attenuation system prevents engine damage during transportation
- 5 Integral Air-Freight Pallet

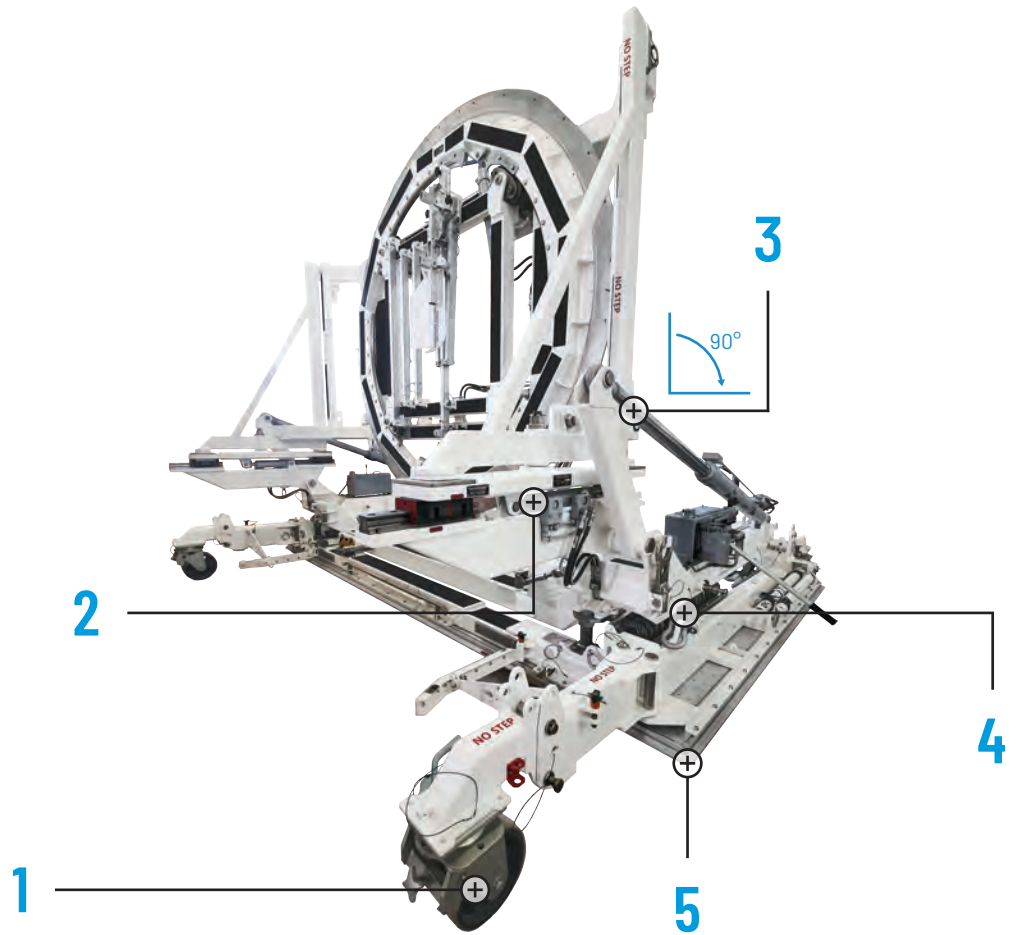

## SPECIFICATIONS

STAND	WEIGHT	DIMENSIONS
EMPTY	15,432 lbs (7,000 kg)	218" L x 196" W x 85" H (5,550mm x 4,978mm x 2,150mm)
STAND + FAN (-84)	19,180 lbs (8,700 kg)	196" L x 292" W x 125" H (4,978mm x 7,430mm x 3,170mm)
STAND + FAN (-97)	19,379 lbs (8,790 kg)	196" L x 292" W x 125" H (4,978mm x 7,430mm x 3,170mm)

## INTERFACING EQUIPMENT FOR FULL SES

- SES Container Storage Kit
- SES Stand Lift Adapter
- Full Engine & Stand Lift Beam
- Full Engine & Stand Sling Set
- Parking Trolley
- MVP Bag
- Desiccant Hanger